

Q-Flex[®] QA-1500 Accelerometer

High-g tactical navigation sensor



Providing high-g tactical navigation capability, Honeywell produces the Q-Flex[®] QA1500 primarily for tactical missile guidance applications.

As with the entire Q-Flex family of accelerometers, the QA1500 features a patented Q-Flex[®] etched-quartz-flexure seismic system. An amorphous quartz proof-mass structure provides excellent bias, scale factor, and axis alignment stability.

The integral Q-Flex electronics develops an acceleration-proportional output current providing both static and dynamic acceleration measurements. By use of a customer supplied output load resistor, appropriately scaled for the acceleration range of the application, the output current can be converted into a voltage.

The QA1500 also includes a current- output, internal temperature sensor. By applying temperature-compensating algorithms, bias, scale factor, and axis misalignment performance are dramatically improved. Robust design and quality assurance provides superior reliability.

Features

- High-g acceleration measurement
- Robust shock and vibration capability
- Analog output
- Field-adjustable range
- Four fastener mounting flange
- Internal temperature sensor for thermal compensation
- Built-in self-test

Configuration Drawings

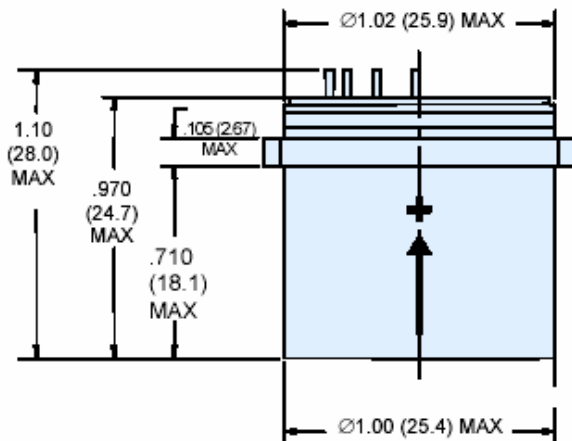
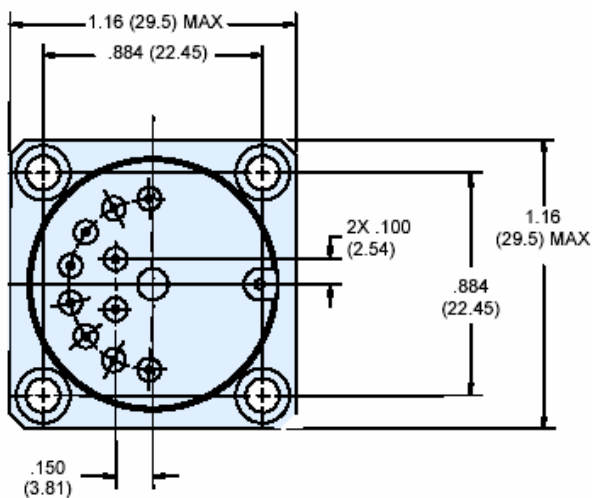

Performance Characteristics

Additional product specifications, outline drawings and block diagrams, and test data are available on request.

Performance	
Input Range [g]	±90
Bias [mg]	<10
One-year Composite Repeatability [µg]	<1500
Temperature Sensitivity [µg/°C]	<100
Scale Factor [mA/g]	0.81 to 0.99
One-year Composite Repeatability [ppm]	<1500
Temperature Sensitivity [ppm/°C]	<200
Axis Misalignment [µrad]	<3000
One-year Composite Repeatability [µrad]	<300
Vibration Rectification [µg/g ² rms]	<20 (50-500 Hz) <70 (500-2000 Hz)
Intrinsic Noise [µg-rms]	<10 (0-10 Hz) <100 (10-500 Hz) <4000 (500-10,000 Hz)
Environment	
Operating Temperature Range [°C]	-55 to +80
Shock [g]	385
Vibration Peak Sine [g]	25 @ 20-2000 Hz
Resolution/Threshold [µg]	<1
Bandwidth [Hz]	>300
Thermal Modeling	
	YES
Electrical	
Quiescent Current per Supply [mA]	<16
Quiescent Power [mW] @ ±15 VDC	<480
Electrical Interface	Temp Sensor Voltage Self Test Current Self Test
Input Voltage	±13 to ±18
Physical	
Weight [grams]	<65
Diameter below mounting surface [inches]	Ø1.000 Max
Height - bottom to mounting surface [inches]	0.710 Max
Case Material	300 Series Stainless Steel

Find out more:
www.inertialsensor.com

Defense & Space Redmond

Honeywell International, Inc.
MAIL ADDRESS: P.O. Box 97001
15001 N.E. 36th Street
Redmond, Washington 98073-9701
PHONE: 888 206 1667
FAX: 425 883 2104
www.honeywell.com

EXP027, August 2005
Copyright © 2004, Honeywell
International Inc. All Rights
Reserved. Printed in USA

ISO-9001 Certification Since 1995

DISCLAIMER: Specifications are subject to change without notice. Honeywell reserves the right to make changes to any product or technology herein to improve reliability, function, or design. Honeywell does not assume any liability arising out of the application or use of the product.

Accelerometers exported from the United States must be done in accordance with the Export Administration Regulations (EAR) and/or the International Traffic in Arms Regulations (ITAR) as applicable.

